

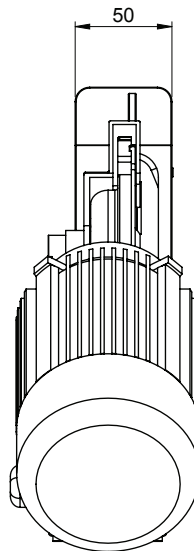

DIMENSION LAYOUT

mod. GRT12SX

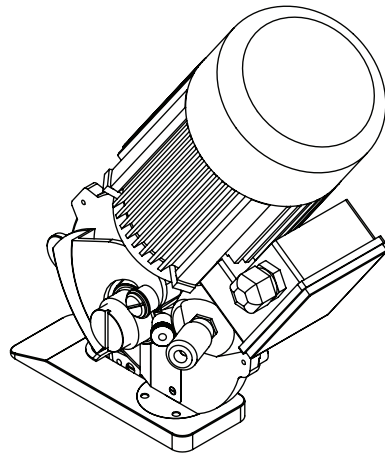
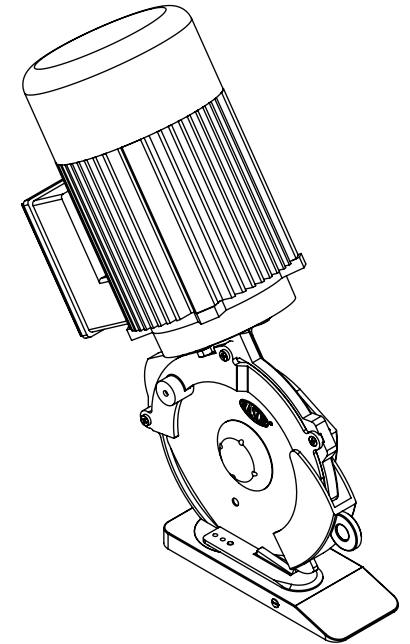
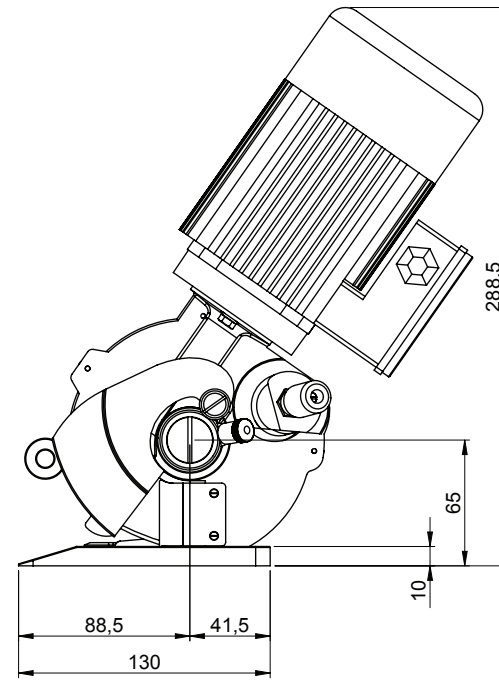
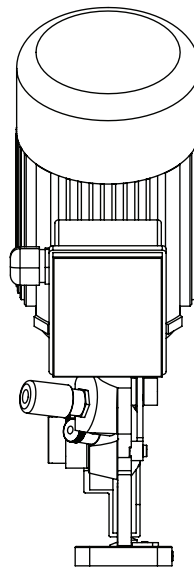
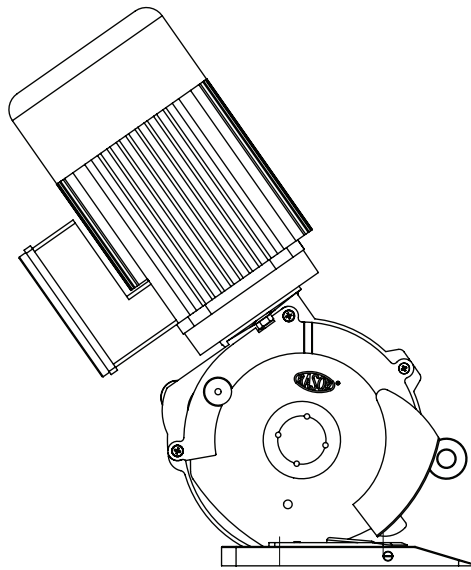

Tolleranze generali per quote di lavorazione							Rugosità Ra UNI 3963			
Fino a:	>6	>30	>120	>315	>1000	>2000	>4000	$\sqrt{\text{Ra}}$	$\sqrt{\text{Ra}}$	$\sqrt{\text{Ra}}$
	±0.1	±0.2	±0.3	±0.5	±0.8	±1.2	±2	0.2	0.4	0.8
	±0.1	±0.2	±0.3	±0.5	±0.8	±1.2	±2	0.2	0.4	0.8

Senza apposite indicazioni fare riferimento alla norma UNI-ISO 2768 - m. Tutti gli spigoli s'intendono sbavati con smusso o arrotondamento di 0,5 mm

REVISIONE	04	-		
	03	-		
	02	-		
	01	-		
SCALA	1:2.5	TRATTAMENTO SUPERFICIALE	MODELLO	N° PEZZI
		-	-	-
DATA	29/06/2013	TRATTAMENTO TERMICO	MATERIALE	PESO KG
		-	-	2.48
DISEGNATO	TCR	MACCHINA	CODICE	S/N
		GRT12SX	GRT12SX	00
VERIFICATO	RSR	DESCRIZIONE	N° DISEGNO	S/N
		ASSIEME GENERALE	A-GRT 12SX D 0001	00