

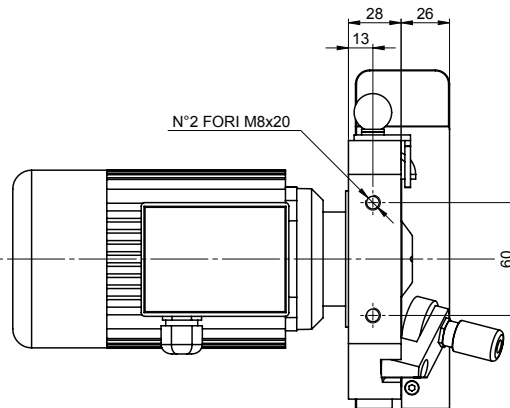

# DIMENSION LAYOUT

## mod. DD120ML

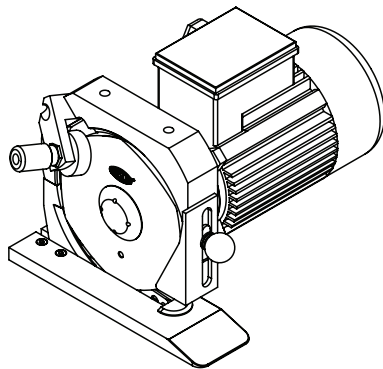
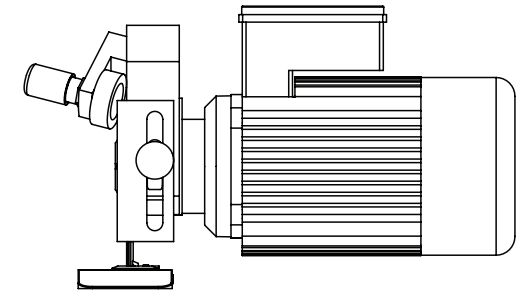
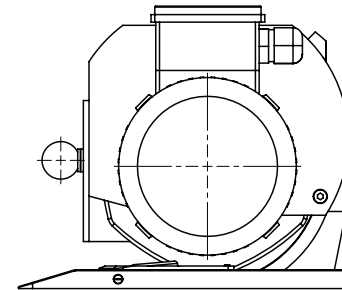
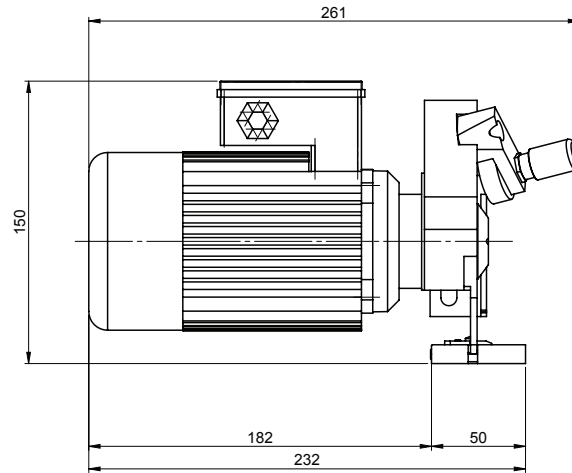
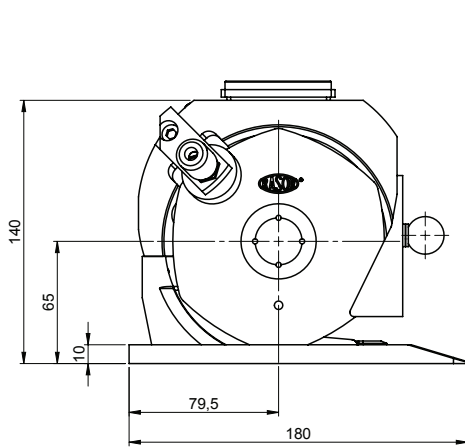
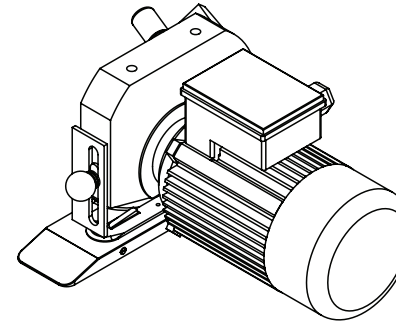
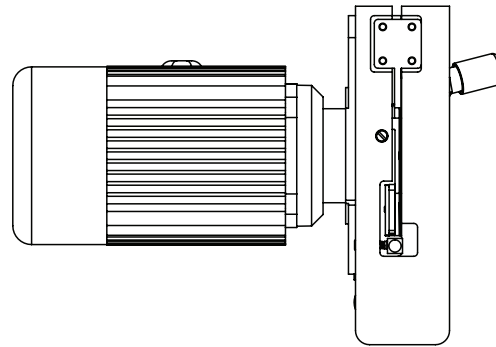

Tolleranze generali per quote di lavorazione								Rugosità Ra UNI 3963		
Fino a:	>6	>30	>120	>315	>1000	>2000	>4000			
5	±0.1	±0.2	±0.3	±0.5	±1.2	±2	±3	0.2	0.5	0.8
								0.2	0.5	0.8

Senza apposite indicazioni fare riferimento alla norma UNI-ISO 2768 - m. Tutti gli spigoli s'intendono sbavati con smusso o arrotondamento di 0,5 mm

REVISIONE	04	-		
	03	-		
	02	-		
	01	-		
SCALA	1:2	TRATTAMENTO SUPERFICIALE	MODELLO	N° PEZZI
DATA	10/01/2019	TRATTAMENTO TERMICO	MATERIALE	PESO KG
DISEGNATO	TCR	MACCHINA	CODICE	S/N
VERIFICATO	RSR	DD120ML	DD 120 ML	00
		ASSIEME GENERALE	N° DISEGNO	S/N
			A-DD120ML D 0001	00