



1946

NERA

BATTERY SCISSORS



USE MANUAL

Razor® Elettromeccanica S.r.l. was established in Milan in 1946 by Luigi Spinelli. For more than sixty years it has been producing automatic cutting systems, cutting units for textile applications and electric and pneumatic cutters.



Initially considered as a point of reference for cutting systems in the textile applications, the Razor® products are nowadays widely used in other fields: chemical, automotive, nautical and sport sectors and in furniture manufacturing.

Nowadays Razor® can rely on the professional continuity of two generations, with the experience inherited from the promoting partner, with his passion and dedication.

The main characteristic of Razor® is that each working phase, starting from the manufacturing of the product up to its packing and delivery is carried out in Razor® premises by qualified operators who have professionally grown up following the spirit of the company and of its founders. This ensures the high quality which Razor® has always considered as essential since the beginning of its activity.

Following the innovative spirit mentioned above, our company is constantly focused on the improvement of the product quality, on the study and development of new materials and technologies.

ACKNOWLEDGMENT

Dear Customer,

thank you for choosing a Razor® Elettromeccanica S.r.l. product.

Razor® has been a reference point in the field of cutting systems in the textile, clothing, furniture, tailoring, sport, chemical, automotive, nautical and insulating material sectors for years. Its production has been always synonymous with reliability attested by many of satisfied customers.

Razor® quality system supervises all the company activities in order to provide the Customer with a service that meets its needs and expectations in terms of product quality, delivery reliability and stock of finished products.

All the parts of the devices have been planned and produced to guarantee an optimum performance. In order to keep the high quality level and the long reliability of the Razor® products, it is recommended using only original spare parts and to contact the head office for any maintenance work.

1. GENERAL SAFETY RULES



This manual is an integral part of battery scissors NERA and must be carefully read before using it, since it gives important indications with regards to its safe installation, use and maintenance. Keep it with care.



Before using battery scissors NERA, read carefully the following general safety rules.

- **PACKAGING.**
After taking off the packaging make sure that the battery scissors are intact. In case of doubt do not use them and contact an authorized service centre. Do not leave pieces of packaging (plastic bags, foam polystyrene, boxes, etc.) within the reach of children or disabled persons, since they are potential sources of danger.
- **AVOID DANGEROUS ENVIRONMENTS.**
Prevent the battery scissors NERA components from coming in contact with damp or wet surfaces.
- **KEEP CHILDREN AWAY.**
Unauthorized persons, in particular children, must be kept away from the working area.
- **KEEP THE WORKING AREA ALWAYS IN ORDER.**
The workplace must always be kept in order and well lightened; liquids or oil traces must not be present.
- **ALWAYS USE BATTERY SCISSORS NERA PROPERLY.**
Use the battery scissors only to carry out the works they have been designed for; do not use them improperly.
- **OBSERVE THE USE OF THE TOOLS.**
Do not cut excessively thick materials and always check blade conditions.
- **AVOID ACCIDENTAL STARTINGS.**
Before connecting battery scissors NERA, make sure that everything is installed properly.
- **CLOTHING.**
Do not use large clothes or accessories that might get stuck in the moving parts.
- **GOGGLES AND PROTECTIVE METAL MESH GLOVES.**
Always use goggles, protective metal mesh gloves approved by Rasor® during use and maintenance operations (according to UNI EN 388:2017 standard).
- **SPARE PARTS.**
During maintenance and replacement operations use only original spare parts. Blade maintenance must be only performed by Rasor® technicians.
- **INSTALLATION.**
Any installation that is not in conformity with these specifications could jeopardize your safety and cancels the warranty.

Informative letter

The installer and the maintenance man must know the content of this manual. Although the main features of the equipment described in this manual are not subject to change, **Rasor® Elettromeccanica S.r.l.** reserves the right to modify the components, details and accessories it deems necessary to improve the product or to meet manufacturing or commercial requirements at any time and without being obliged to update this manual immediately.



WARNING



ALL RIGHTS ARE RESERVED ACCORDING TO THE INTERNATIONAL COPYRIGHT CONVENTIONS,

The reproduction of any part of this manual, in any form, is forbidden without the prior written authorization of Rasor® Elettromeccanica S.r.l.

The content of this guide can be modified without prior notice. Great care has been taken in collecting and checking the documentation contained in this manual to make it as complete and comprehensible as possible.

Nothing contained in this manual can be considered as a warranty, either expressed or implied - including, not in a restrictive way, the suitability warranty for any special purpose. Nothing contained in this manual can be interpreted as a modification or confirmation of the terms of any purchase contract.

Rasor® Elettromeccanica S.r.l. products have not been conceived to work in areas at risk of explosions and at high risk of fire and they cannot cut wet or damp materials. Moreover, they cannot work in case of rain.

In case of damage or malfunction, battery scissors NERA must not be used until the Customer Care Technical Service has repaired them.

Customer Care Technical Service



For any information, please contact
RASOR® ELETTRMECCANICAS.r.l.
Via V. Caldesi, 6; 20161, MILANO (MI) - ITALY
Phone: +39.02.66221231; Fax: +39.02.66221293
e-mail: info@rasor-cutters.com
web: www.rasor-cutters.com

WARNING



The original configuration of the battery scissors must not be changed at all.

On receiving them, make sure the supply corresponds to what has been ordered.

In case of non-compliance immediately inform Rasor®.

Also make sure the scissors have not been damaged during transport.



2. TRANSPORT AND PACKING

The scissors are delivered in a cardboard with the batteries and the charger. The code of the ordered product and its serial number are indicated outside the package (see picture 1). The following accessories are also contained inside the cardboard (see picture 2):

- 1) Hexagonal blade (6 sides);
- 2) Drift for blade assembly/disassembly;
- 3) Butterfly wrench for blade nut disassembly.
- 4) Rechargeable 3.7V battery with Lithium® Ion technology (x 2);
- 5) Standard charger with European or American plug;
- 6) Charging docking station for 3.7 V batteries with Lithium® Ion technology.

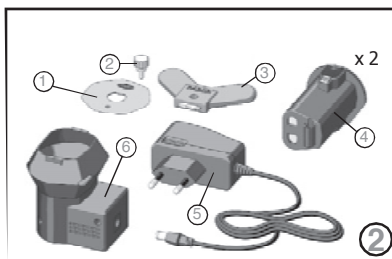

3. PLATE DATA

The manufacturer's identification and Machinery Directive 2006/42/EC conformity plate (see picture below) is located on the front part of the battery scissors.

The plate must not be removed at all, even if the equipment is resold. Always refer to the serial number (written on the plate itself) when contacting the manufacturer.

Several safety warnings are printed on a card which is applied to the battery scissors; such warnings must be strictly followed by everyone dealing with the equipment. **The company is not to be held responsible for damage to property or accidents to people which might occur if the above-mentioned warnings are not observed. In such a case, the operator is the only person responsible.**

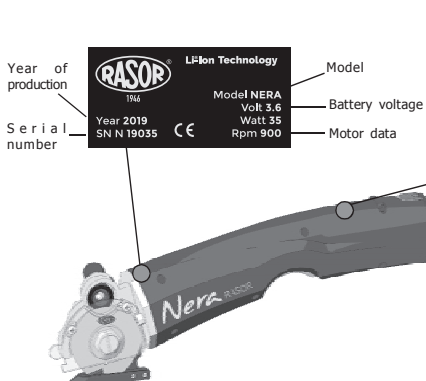

4. PRODUCT DESCRIPTION

EN
6

This manual describes battery scissors model NERA which are used in order to cut fabrics in the textile industry, technical fabrics and light leathers. They are extremely versatile, light and precise in the cutting operation. The 3.7 V Lithium®-ion battery-powered miniature motor, extremely compact and reliable, combined with a special series of blades with a diameter of 50 mm, ensures cuts of thickness up to 9 mm. The Lithium® Ion battery develops 2400 mAh and is easily rechargeable with the appropriate docking station complete with LED indicator. The second battery, included in the package, allows you to cut continuously without interrupting the work. The strong cutting foot with a thin shape allows the cutting of curved profiles with great ease. One of the peculiarities of the battery scissors NERA is the possibility, thanks to the presence of a grinding wheel mounted on the scissors, to be able to sharpen the blade at any time, without disassembling it. After carrying out this operation, it is possible to immediately resume cutting operations. A perfectly balanced motor, with a high number of revolutions and maintenance-free, reduces vibrations to a minimum, making the battery scissors compliant with the European Directive 2002/44/EC on the risks deriving from mechanical vibrations. The mechanical parts are made of high quality steel, bronze and aluminum and require lubrication after several working hours.

Device components

1	Start button	9	Blade protection guard
2	Battery Li-Ion 3,7V	10	Motor support
3	Plastic motor casing	11	Adjusting perpetual screw
4	Steel foot	12	Reference point
5	Steel polygonal blade	13	Carbide counterblade
6	Grease cup	14	Plate locking the threads
7	Emery grinding wheel	15	Upper and lower buttons for battery disconnection
8	Sharpening button		

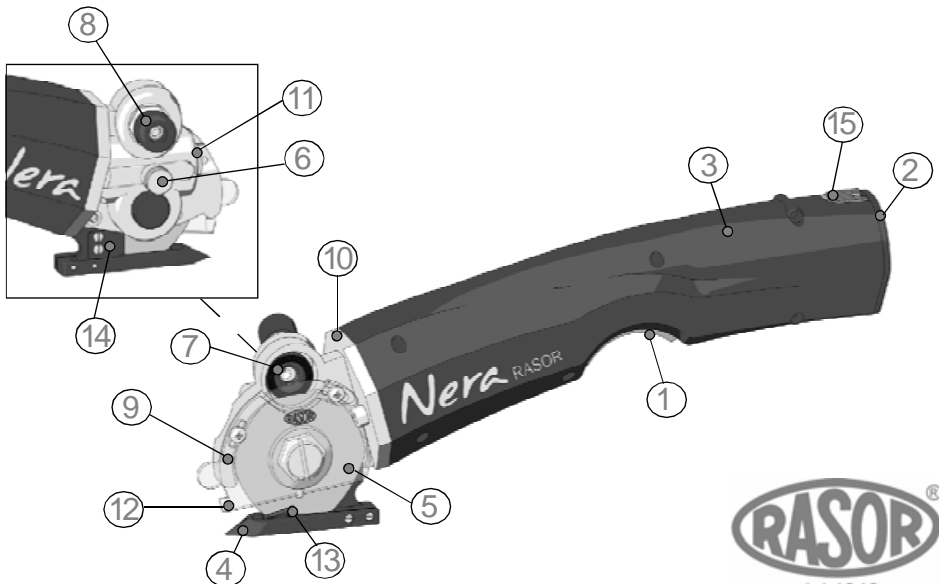

5. TECHNICAL FEATURES

Battery scissors NERA features	
Blade diameter	50 mm with carbide counterblade
Blade supplied	50EEXT, EXTRA steel hexagonal blade
Blade speed	900 revolutions/min
Cutting working depth	about 9 mm
Motor power	DC 3,7 V - 35 W
Battery	Li-Ion 3,7 V, 2,4 Ah rechargeable
Weight (with battery)	580 g
Weight with package	950 g
Minimum luminosity for working operations	LUX 200
Vibrations at the start up	< 2.5 m/s ²
Temperature	0 ~ 55°C
Humidity	10 ~ 95% without condensate

Features of the available blades	
503EEXT	EXTRA steel hexagonal blade
503EHSS	HSS steel hexagonal blade
503CHSS	HSS steel circular blade
503DHSS	HSS steel decagonal blade
503DHSSTF	HSS steel decagonal blade covered with Teflon®
503EHSSTF	HSS steel hexagonal blade covered with Teflon®

EN
7

The technical data is only indicative and it can be changed without notice

6. NOISE LEVEL

The maximum acoustic pressure level emitted by battery scissors NERA is about 60 dB (A). Noise tests have been carried out in compliance with Standard UNI EN ISO 11202:2010. The device noise levels, measured at different distances (without any sound wave filtering system), vary in the extent of few db (A).

NOTE

It is advisable for battery scissors NERA owners to verify the compliance with the standard concerning safety of workers: Italian legislative decree 81/08.

7. FIELD OF APPLICATIONS

Battery scissors NERA have been designed, manufactured and assembled to cut every kind of fabrics or materials, with the exception of metal, plastic or wood, by means of rotary blades.

This equipment must not work:

- in areas prone to explosions;
- in presence of fine dust or corrosive gases;
- to cut plastic, metal and wooden materials.

It is forbidden to use battery scissors NERA for purposes different from the above-mentioned ones.

8. USE WARNINGS

We recommend following the indications below in order to always work in safety conditions.

- All the operations must be carried out complying strictly with the safety rules of the country where the device is sold.
- It is **STRICTLY FORBIDDEN** to smoke during the installation or adjustment operations of the battery scissors.
- The Customer undertakes to comply with and make his staff observe all the rules and regulations in force concerning safety, prevention of accidents and health in the work place. Therefore, the Customer assumes the responsibility to strictly follow all the rules and regulations in force, as well as the special provisions in force in sport and public installations the Customer declares to know after receiving all the relative necessary pieces of information.
- **The battery scissors work also without their safety protective device. This protective device must NEVER be removed.**
- Always check the resistance of the material to be cut and the kind of blade which is being used.
- The Customer shall equip his own personnel with all the individual safety protections for the execution of the works, as well as with the ones which might be prescribed by the Manufacturer due to specific danger conditions of the plant or of the area where the personnel must work.
- Only one operator must use the battery scissors always standing behind the guide handle. Do not make any adjustment while the blade is working.
- It is allowed to assemble battery scissors NERA on machines O.E.M. on condition that their original structure is not modified. Otherwise, the intervention must be certified by Rasor®.

9. RESIDUAL RISKS

Even though the battery scissors are safe, operators must pay attention to preserve their and other people's safety.

- ☹ At the end of the working operations, the metallic components could be very hot.
- ☹ The cutting blade can work even when the protective device is disassembled.

10. RULES FOR THE CARE OF THE LITHIUM-ION BATTERIES

The following rules should be noted when caring for your lithium-ion batteries if you want to maintain the performance of the energy store for as long as possible:

- The first charge is crucial. Fully charge the battery before using it for the first time.
- Each battery only has a limited number of charge cycles. Don't therefore recharge the battery at every opportunity. Instead use it until it is almost flat (10-20% of charge). Depending on loading, the high-quality, 2,4 Ah capacity battery cells can be charged up to 500 times. Assuming 150 days are worked a year and that the batteries are charged daily, this corresponds to a battery life of 2 years.
- If the battery is discharged below its nominal voltage, this can trigger processes which damage or destroy the battery. The batteries are therefore fitted with electronics which warn the user and shut down the device before total discharge can take place.
- Frequent overcharging can also permanently damage the battery. The charger therefore automatically finishes the charging process as soon as the battery is fully charged. Do not attempt to force more charge into the batteries by unplugging and reconnecting the charger. Such action will not produce a higher charge - it will only damage the batteries.
- Charging should generally only be undertaken at room temperature (around 18 - 21 degrees). Avoid charging a cold battery as it damages the cells. Always warm the battery up to room temperature before charging, especially when it is cold outdoors in winter.
- High temperatures also damage the battery. Never leave the battery, and preferably not the entire tool box, in the car or direct sunlight on hot sunny days. At temperatures above 60 degrees Celsius, the Li-ion battery permanently loses capacity.
- Lithium-ion batteries shouldn't be stored flat or fully charged for long periods. Extensive testing has found a capacity of 40-50 % and low temperatures (but not below 0°C) to be optimum for storage. Ideally they should be kept at 5°C to 10°C. Recharging is needed at least every 12 months as the batteries will self-discharge.
- A battery which is not being used should be stored in a cool but not cold place. Even when not being used, batteries lose energy. The Li-ion battery loses 3-5% of its charge a month.
- If a lithium-ion battery is not used for a long period, it should be recharged after 12 months at the latest otherwise it will be irreparably damaged.
- Old, used batteries must of course be disposed of in an environmentally friendly manner.

11. USE

To use the battery scissors manually, proceed as follows:

- 1) Release the battery (if it is charged) from the charger as described at paragraph 12;
- 2) Connect the battery to the motor and fix it following the slots on the battery;
- 3) Lay the material to be cut on a table;
- 4) Put the material on the cutting foot (see picture 3);
- 5) Press the button under the handle to start the scissors;
- 6) Push the battery scissors in the desired direction, being careful to keep the material in front of them as stretched as possible and preventing it from curling in the front part of the scissors.

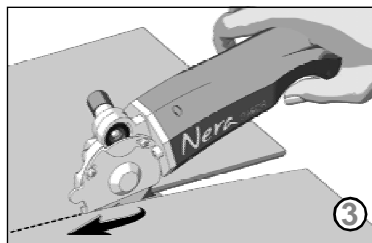

EN
10

NOTE

The thrust on the battery scissors must be as uniform as possible. To carry out linear cuts with precision (and to follow predetermined paths), we also recommend using the arrow point (see point "A" in picture 4).

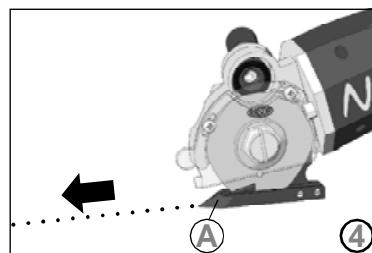

12. BATTERY CHARGING

When the battery is empty, it is necessary to recharge it using only the special docking station supplied with the device.

The docking station must be connected to the standard charger with European or American plug, also supplied with the scissors.

WARNING

Always check if the charger voltage corresponds to the network voltage of the country where the scissors are used.

WARNING

Never use chargers other than those supplied (100-240VAC, 50/60 Hz, 0.4A max - Output: 4,2V, 2A).

Remove the battery "A" from the motor by pressing the appropriate orange "B" buttons on the top and bottom of the battery (see picture 5), then insert it into the "C" docking station as shown in picture 6.

Never use batteries other than the one supplied (3,7V rechargeable with Lithium[®] Ion technology).

It is possible to control the recharging operation through the LED light located on both the docking station and the charger. These LEDs indicate:

- battery charging (red colour)
- fully charged battery (green colour)

Using the standard charger CH36 (with European plug) or CH3601 (with American plug), the time required for a full charge is approx. 4 hours.

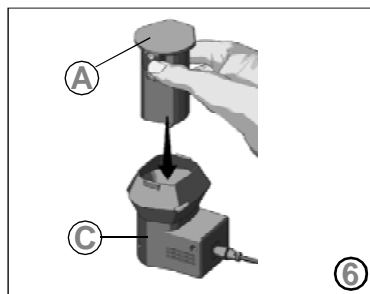
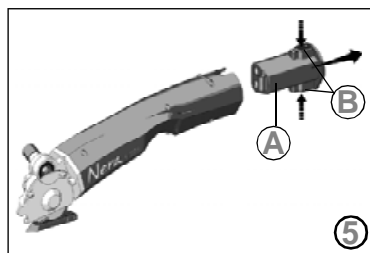

13. BLADE SHARPENING

After many hours of a continuative use of the battery scissors or if they are not able to cut anymore, it is necessary to sharp the blade. To carry out this operation, start the blade and press sharpening button "1" for 3-4 seconds (as shown in picture 7). Repeat this operation 2-3 times.

EN
12

If the sharpening process should be ineffective, check the wear of the emery grinding wheel "2" (see picture 7). If wheel "2" is too worn or dirty, replace it by removing the blade by means of the proper tool.

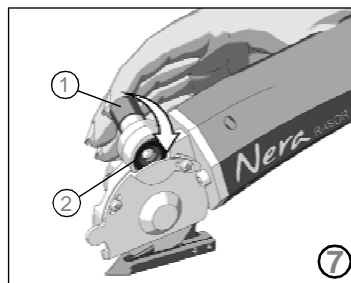

14. LUBRICATION

Every 3-4 working days, it is necessary to lubricate the gear pair. In order to carry out this operation, remove protective plug "A" located on the head of the battery scissors and fill it with the grease supplied. Screw plug "A" again a few turns. Screw plug "A" a few turns every day (see picture 8).

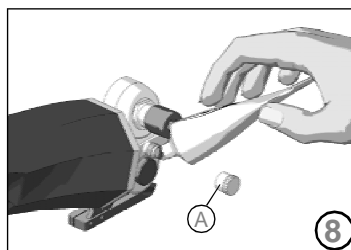

WARNING



The blade must never be dirty with grease or oil.

15. BLADE REPLACEMENT

If the blade is no more able to cut (even after repeating the sharpening operation several times) it is necessary to replace it. In order to carry out this operation, use butterfly wrench "1" and drift "3" locking the blade (shown in picture 9). In order to replace the blade, proceed as follows:

- 1) Disconnect the battery from the machine;
- 2) Use some protective gloves in compliance with Italian Legislative Decree 81/08.
- 3) Remove safety protection "B", by unscrewing the two slotted screws "A" by means of a screwdriver (not supplied by the manufacturer), as shown in picture 10.
- 4) Insert drift "3" (see picture 11) into hole "C" in order to lock the blade (the hole in the blade must correspond to the hole in the structure).
- 5) Use butterfly wrench "1" in order to unscrew nut "D" and remove blade "E" (see picture 12).
- 6) Replace the worn blade with the new one "2", being careful to center the blade on the gear, in the correct position, and remember to assemble it with its sharp side (the one with the writing Rasor) positioned towards the external side of the battery scissors.
- 7) Assemble all the components again and carry out some cutting and sharpening tests.

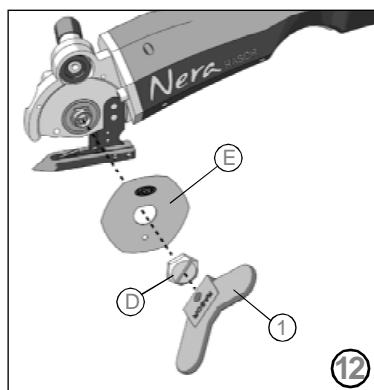
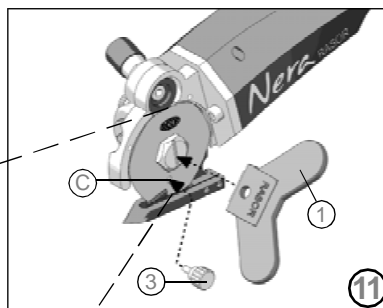
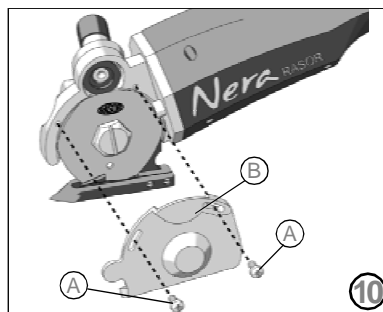
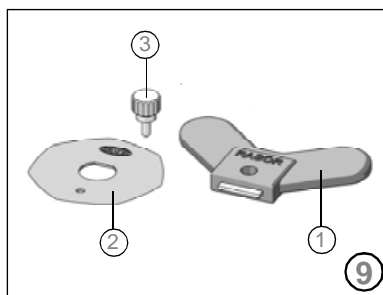

16. TROUBLESHOOTING

EN
14

PROBLEM	SOLUTION
The fabric is not cut or it gets stuck between the blade and the counterblade	Verify that the blade and the counterblade are in contact with each other and that the counterblade has no material residues
	Check the counterblade integrity
	Check the kind of fabric
	Sharpen the blade
	Check the fabric thickness
	Check the compatibility between blade and fabric
	Make sure that the motor turns correctly
	Check the battery charge
	Reduce the feeding speed
	Carry out the lubrication
The electric scissors are noisy	Disassemble the blade and remove the material residues
The scissors start slowly, work intermittently or do not start	Check the correct insertion of the battery
	Check the integrity of the plastic joint
	Check the battery charge

17. SPARE PARTS / EXPLODED VIEW

CODE	DESCRIPTION	CODE	DESCRIPTION	CODE	DESCRIPTION	CODE	DESCRIPTION
503EEXT	EXTRA STEEL HEXAGONAL BLADE, 50 mm	F 5029	5x11x4 GEAR SCREW BEARING	F 5042	RING NUT FIXING THE BLADE	F 5074	PLATE WITH EMERY
BA 011	MOTOR FLANGE	F 5029/1	CRINKLE WASHER	F 5057	DRIFT LOCKING THE BLADE	F 5074CPL	COMPLETE EMERY GRINDING WHEEL UNIT
BA 012	ELECTRIC MOTOR WITH SPEED REDUCT ION GEAR	F 5029/2	SEGER RING	F 5059	WRENCH FOR BLADE DISASSEMBLY	F 5075	EMERY GRINDING WHEEL BUSH
BA 012CPL	COMPLETE MOTOR NERA504	F 502901	5x13x4 GEAR SCREW BEARING	F 5065	SCREW FIXING THE FOOT	F 5076	WASHER
BA 013	PLASTIC MOTOR CAP RIGHTS	F 503101	ADJUSTING RING NUT	F 5066	PLATE LOCKING THE THREADS FASTENING SCREW	F 5077	SPRING INSIDE THE SHARPENING BUTTON, Ø 6 mm
BA 014	PLASTIC MOTOR CAP LEFT	F 5032	GEAR RING CENTRAL PIN	F 5067	PLATE LOCKING THE THREADS	F 5078	SPRING INSIDE THE SHARPENING BUTTON, Ø 9 mm
BA 015	MOTOR CAP FASTENING SCREW	F 5033	GREASER CAP	F 5068	WIDIA COUNTERBLADE WITH SPRING	F 5079	SHARPENING BUTTON
BA 016	PLASTIC BUTTON	F 5034	GREASING CUP	F 5069	SCREW FIXING THE COUNTERBLADE	F 5080	SCREW FIXING THE SHARPENING BUTTON
BA 017	BUTTON SPRING	F 5036	SHIM ADJUSTMENT WASHER	F 5070	STEEL FOOT	F 5082	GEAR ENDLESS SCREW
BA 018	STARTING BUTTON	F 5037	RING NUT FIXING THE BEARING	F 5070CPL	COMPLETE FOOT	F 5082CPL	COMPLETE ENDLESS SCREW
BA 019	CONTACT TERMINALS	F 5038	GEAR RING BEARING	F 5071	BLADE PROTECTION GUARD	F 5083CPL	COMPLETE GEAR CROWN
BA 020	REDUCER FLANGE FIXING SCREW	F 5040	SCREW FIXING THE GEAR RING	F 5071/1	SCREW FIXING THE BLADE PROTECTION GUARD	F 5084CPL	COMPLETE MOTOR SUPPORT
BA 021	ENGINE SUPPORT FASTENING SCREW					F 5084SET	COMPLETE CUTTING PART
F 5027	JOINT					FRNN504	NERA COMPLETE ACCESSORY SET

OPTIONAL ACCESSORIES

CODE	DESCRIPTION
BAT36	3.7 V, 2400 mA Li-Ion® BATTERY
DK36	DOCKING STATION
CH36	100-240 V CHARGER EU PLUG
CH3601	100-240 V CHARGER US PLUG

WARRANTY

Rasor® Elettromeccanica S.r.l. battery scissors have a 12 month warranty from the date indicated on the last page of this manual, except in case of different written agreements. The warranty covers all manufacturing and material defects. Replacement and repair operations are covered only if carried out by our company and at our workshop. If in-warranty goods need to be repaired, **the customer must always send the complete machine to Rasor®**. **Single units will not be repaired under warranty.**

The material to be repaired must be sent CARRIAGE FREE.

Once the equipment has been repaired, it will be sent CARRIAGE FORWARD to the customer. The warranty covers neither technicians' intervention on the site where the battery scissors are used nor their disassembly.

If for practical reasons, one of our technicians is sent to the premises, the customer will be charged the costs plus the travelling expenses.

The warranty does not include:

- failure caused by wrong use or assembly,
- failure caused by external agents,
- failure caused by lack of maintenance or negligence;
- blades and parts subject to wear.

WARRANTY FORFEITURE:

In case of arrearage or other breaches of contract,

Whenever changes or repairs are carried out on our battery scissors without our prior authorization,

Whenever the serial number is tampered with or cancelled,

Whenever the damage is caused by improper use, bad treatment, bumps, falls and other causes not due to normal working conditions,

Whenever the unit seems tampered with, dismantled or previously repaired by unauthorized staff,

In case the battery scissors are used for purposes that are different from the ones described in this manual.

In case non-original Rasor® spare parts are installed.

All repair operations carried out under warranty do not interrupt its duration.

All disputes will be settled in the court of justice of Milan (Italy).

We thank you in advance for the attention you will pay to this manual and we invite you to inform us of any change you deem necessary to improve it and make it more complete.

RASOR ELETTROMECCANICA SRL

Via Vincenzo Caldesi 6

20161 Milan · Italy

ph. +39 02 66 22 12 31

fax +39 02 66 22 12 93

info@rasor-cutters.com

www.rasor-cutters.com

FOLLOW US:

