

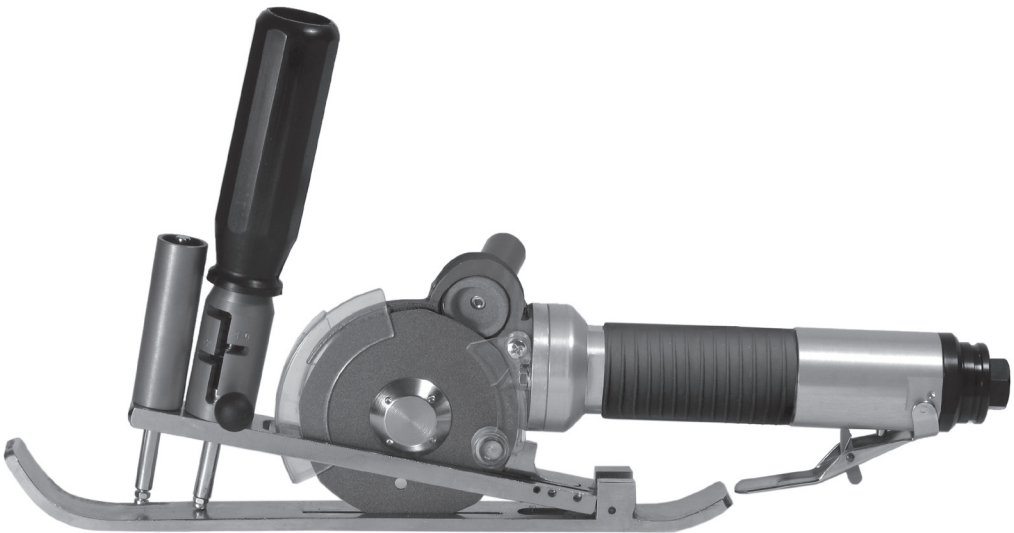

1946

FP861RC

PNEUMATIC SCISSORS



USE MANUAL

Rasor® Elettromeccanica S.r.l. was established in Milan in 1946 by Luigi Spinelli. For more than sixty years it has been producing automatic cutting systems, cutting units for textile applications and electric and pneumatic cutters.



Initially considered as a point of reference for cutting systems in the textile applications, the Rasor® products are nowadays widely used in other fields: chemical, automotive, nautical and sport sectors and in furniture manufacturing.

Rasor® can rely on the professional continuity of three generations, thanks to the precious support of the promoting partner, to his passion, dedication and great experience of seventy years.

The main characteristic of Rasor® is that each working phase, starting from the manufacturing of the product up to its packing and delivery is carried out in Rasor® premises by qualified operators who have professionally grown up following the spirit of the company and of its founders. This ensures the high quality which Rasor® has always considered as essential since the beginning of its activity.

Following the innovative spirit mentioned above, our company is constantly focused on the improvement of the product quality, on the study and development of new materials and technologies.

ACKNOWLEDGEMENT

Dear Customer,

thank you for choosing a Rasor® Elettromeccanica S.r.l. product.

Rasor® has been a reference point in the field of cutting systems in the textile, clothing, furniture, tailoring, sport, chemical, automotive, nautical and insulating material sectors for years. Its production has been always synonymous with reliability attested by many of satisfied customers.

Rasor® quality system supervises all the company activities in order to provide the Customer with a service that meets its needs and expectations in terms of product quality, delivery reliability and stock of finished products.

All the parts of the devices have been planned and produced to guarantee an optimum performance. In order to keep the high quality level and the long reliability of the Rasor® products, it is recommended using only original spare parts and to contact the head office for any maintenance work.

1. GENERAL SAFETY RULES



This manual is an integral part of pneumatic scissors FP861RC and must be carefully read before using it since it gives important indications with regards to its safe installation, use and maintenance. Keep it with care.



Before using pneumatic scissors FP861RC, read carefully the following general safety rules.

EN
19

- **PACKAGING.**
After taking off the packaging make sure that the machine is intact. In case of doubt do not use it and contact an authorized service centre. Do not leave pieces of packaging (plastic bags, foam polystyrene, boxes, etc.) within the reach of children or disabled persons since they are potential sources of danger.
- **AVOID DANGEROUS ENVIRONMENTS.**
- **KEEP CHILDREN AWAY.**
Unauthorized persons, in particular children, must be kept away from the working area.
- **KEEP THE WORKING AREA ALWAYS IN ORDER.**
The workplace must always be kept in order and well lightened; liquids or oil traces must not be present.
- **ALWAYS USE PNEUMATIC SCISSORS FP861RC PROPERLY.**
Use the scissors only to carry out the works they have been designed for; do not use them improperly.
- **OBSERVE THE USE OF THE TOOLS.**
Do not cut excessively thick materials and always check blade conditions.
- **AVOID ACCIDENTAL STARTINGS.**
Before connecting pneumatic scissors FP861RC, make sure that everything is installed properly.
- **CLOTHING.**
Do not use large clothes or accessories that might get stuck in the moving parts.
- **GOGGLES AND PROTECTIVE METAL MESH GLOVES.**
Always use goggles, protective metal mesh gloves approved by Rasor® during use and maintenance operations (according to UNI EN 388:2004 standard).
- **SPARE PARTS.**
During maintenance and replacement operations use only original spare parts. Blade maintenance must be only performed by Rasor® technicians.
- **INSTALLATION.**
Any installation that is not in conformity with these specifications could jeopardize your safety and cancels the warranty.

Informative letter

The installer and the maintenance man must know the content of this manual. Although the main features of the machine described in this manual are not subject to change, **Rasor® Elettromeccanica S.r.l.** reserves the right to modify the components, details and accessories it deems necessary to improve the machine or to meet manufacturing or commercial requirements at any time and without being obliged to update this manual immediately.



WARNING



ALL RIGHTS ARE RESERVED ACCORDING TO THE INTERNATIONAL COPYRIGHT CONVENTIONS,

The reproduction of any part of this manual, in any form, is forbidden without the prior written authorization of Rasor® Elettromeccanica S.r.l.

The content of this guide can be modified without prior notice. Great care has been taken in collecting and checking the documentation contained in this manual to make it as complete and comprehensible as possible.

Nothing contained in this manual can be considered as a warranty, either expressed or implied - including, not in a restrictive way, the suitability warranty for any special purpose. Nothing contained in this manual can be interpreted as a modification or confirmation of the terms of any purchase contract.

Rasor® Elettromeccanica S.r.l. machines have not been conceived to work in areas at risk of explosions and at high risk of fire and they cannot cut wet or damp materials. Moreover, they cannot work in case of rain.

In case of damage or malfunction, pneumatic scissors FP861RC must not be used until the Customer Care Technical Service has repaired them.

Customer Care Technical Service



For any information, please contact
RASOR®ELETTROMECCANICAS.r.l.
Via V. Caldesi, 6; 20161, MILANO (MI) - ITALY
Phone: +39.02.66221231; Fax: +39.02.66221293
e-mail: info@rasor-cutters.com
web: www.rasor-cutters.com



The original configuration of the pneumatic scissors must not be changed at all.

On receiving the machine make sure the supply corresponds to what has been ordered.

In case of non-compliance immediately inform Rasor®.

Also make sure the scissors have not been damaged during transport.



2. TRANSPORT AND PACKING

The pneumatic scissors are delivered in a carrying case, inside which there are various options. The code of the ordered product and its serial number are indicated outside the package (see picture 1). The following accessories are contained in a bag inside the package:

- 1) Octagonal blade (8 sides);
- 2) Butterfly wrench for blade nut disassembly.
- 3) Drift for blade disassembly;
- 4) Rubber hose;
- 5) Lubricating oil (15 ml).

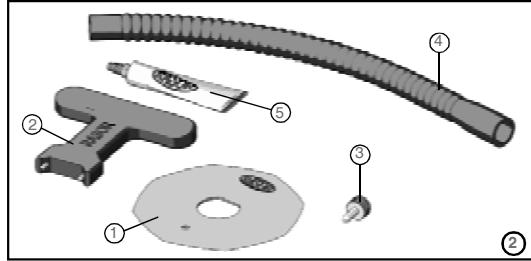

3. PLATE DATA

The manufacturer's identification and EC STANDARD 2006/42/EC conformity plate (see picture below) is located on the front part of the pneumatic scissors.

The plate must not be removed at all, even if the machine is resold. Always refer to the serial number written on the plate itself when contacting the manufacturer. Several safety warnings are printed on a card which is applied on the scissors; such warnings must be strictly followed by everyone dealing with the machine. **The company is not to be held responsible for damage to property or accidents to people which might occur if the above-mentioned warnings are not observed. In such a case, the operator is the only person responsible.**

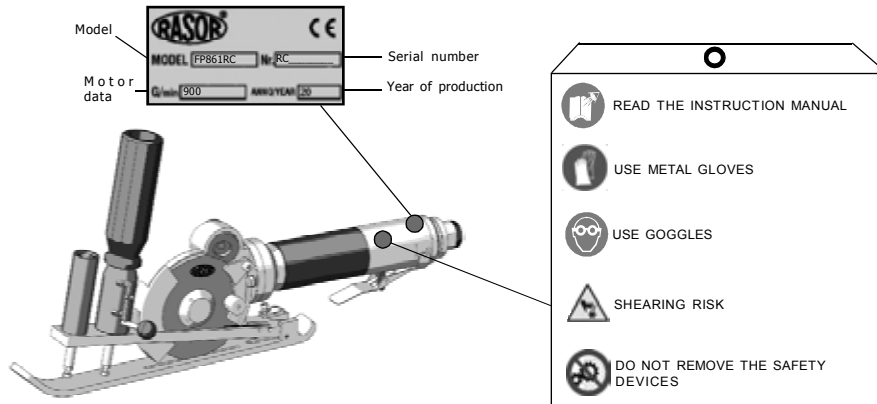

4. PRODUCT DESCRIPTION

The fixture described in this manual is a pneumatic scissor model FP861RC which is used in order to quickly cut paper, fabric and plastic rolls.. It is extremely versatile, light and precise in the cutting operation, suitable also for very difficult cuttings.

On the front part the scissor is provided with a three-position selector that allows adjusting quickly and faultless the desired cut height. Thanks to this selector it is possible to make the blade protrude from the supporting foot at three different heights according to the cut requirements. One special feature of pneumatic scissors FP861RC is their ability to sharpen the blade in each moment without disassembling it by means of a grinding wheel mounted on the scissors head. After carrying out this operation, it is possible to perform immediately the cutting operation. The pneumatic scissors are provided with a threaded connection to the pneumatic circuits. The turbine, perfectly balanced, with a high number of revolutions and totally free of maintenance, reduces the vibrations and the noise to the minimum.

The use of compressed air as source of energy allows working continuously without problems of heating or motor overload. The mechanical parts are made up of steel and high resistant bronze and require a lubrication after many working hours.

Device components

1	1/4" gas connection for the air connector	9	Sharpening button
2	Safet device to enable the control lever	10	Protection guard of the blade (movable)
3	Control lever	11	Handle
4	Supporting foot	12	Motor support
5	Polygonal blade	13	Silencer
6	Greaser	14	Cutting height selector
7	Pneumatic motor	15	Selector adjusting knob
8	Sharpener	16	Bush with return spring

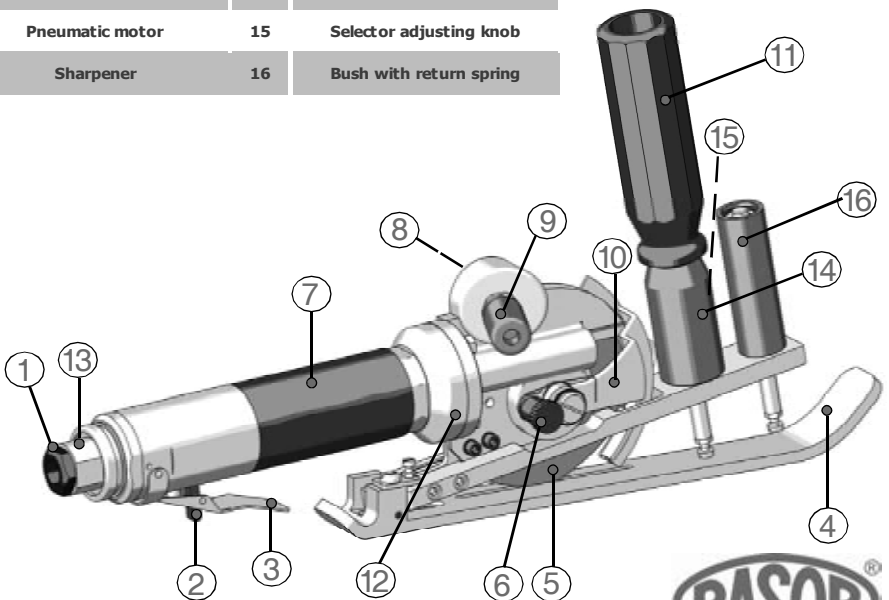

5. TECHNICAL FEATURES

Pneumatic scissors FP861RC features	
Blade diameter	86 mm
Blade speed	900 revolutions/min
Cutting working height	about 20 mm
Power	400 W with maximum pressure
Working pressure	max. 6 bar
Weight	1600 g
Weight with package	3100 g
Air consumption	9 liters/sec.
Minimum luminosity for working operations	LUX 200
Vibrations at the start up	< 2,5 m/s ²
Temperature	0 ~ 55°C
Humidity	10 ~ 95% without condensate

Features of the available blades	
86THSSTF	8 side blade Ø 86 mm, in H.S.S. steel covered with Teflon
86PHSSTN	5 side blade Ø 86 mm, in H.S.S. steel covered with Teflon

EN
23

The technical data are only indicative and they can be changed without notice.

6. RUMOR LEVEL

The maximum acoustic pressure level emitted by pneumatic scissors FP861RC is about 60 dB (A). Noise tests have been carried out in compliance with Standard UNI EN ISO 11202:2010. The device noise levels, measured at different distances (without any sound wave filtering system), vary in the extent of few db (A). The noise level has been detected with the silencer supplied mounted on the discharge unit.

NOTE

It is advisable for pneumatic scissors owners to verify the compliance with the standard concerning safety of workers: Italian legislative decree 81/08.

The use of ear protecting devices is compulsory.

7. FIELD OF APPLICATIONS

Pneumatic scissors FP861RC have been designed, manufactured and assembled to cut every kind of paper or similar materials, fabric and plastic.

This equipment must not work:

- in areas prone to explosions;
- in presence of fine dust or corrosive gases;
- to cut metal and wooden materials.

It is forbidden to use pneumatic scissors FP861RC for purposes different from the above-mentioned ones.

8. USE WARNINGS

We recommend following the indications below in order to always work in safety conditions.

- All the operations must be carried out complying strictly with the safety rules of the country where the machine is to be installed.
- It is **STRICTLY FORBIDDEN** to smoke during the installation or adjustment operations of the pneumatic scissors.
- The Customer undertakes to comply with and make his staff observe all the rules and regulations in force concerning safety, prevention of accidents and health in the work place. Therefore, the Customer assumes the responsibility to strictly follow all the rules and regulations in force, as well as the special provisions in force in sport and public installations the Customer declares to know after receiving all the relative necessary information.
- **The pneumatic scissors work also without their safety protective device and with protection guard lifted. This protective device must NEVER be removed.**
- Always check the resistance of the material to be cut and the kind of blade which is being used.
- The Customer shall equip his own personnel with all the individual safety protections for the execution of the works, as well as with the ones which might be prescribed by the Manufacturer due to specific danger conditions of the plant or of the area where the personnel must work.
- Only one operator must use the pneumatic scissors always standing behind the guide handle. Do not make any adjustment while the blade is working.
- Always pay attention to the air hose position to prevent it from being cut or damaged by the blade.
- It is allowed to assemble pneumatic scissors FP861RC on machines O.E.M. on condition that their original structure is not modified. Otherwise, the intervention must be certified by Rasor®.
- The pneumatic scissors FP861RC are equipped with double safety push button, made up of a lever and a pawl in the handle: the pawl prevents the start push button to be activated accidentally, the lever enables the cutter. Never remove the pawl.

NOTE

The cutting blade protrudes from the bottom of the supporting foot as described in picture 3 on the following page. The materials to be cut must have a higher thickness than the real cutting height. The maximum projection of the blade is 20mm.

9. RESIDUAL RISKS

Even though the pneumatic scissors are safe, operators must pay attention to preserve their and other people's safety.

- ⊗ The cutting blade can work even when the protective guard is disassembled.

10. USE

To use the pneumatic scissors manually, proceed as follows:

- 1) Lay the roll to be cut on the table;
- 2) Position the selector knob "A" on the desired selector notch according to the thickness of the material to be cut (3mm, 10mm or 20mm) (see picture 3);
- 3) Connect the air hose to the quick connection "B" (not supplied) (see picture 4);
- 4) Adjust the pressure gauge (option) on 6 bar;
- 5) Put the material on the roll cutting foot (see picture 4);
- 6) Push the starting lever after moving the safety device (see picture 5);
- 7) Push the pneumatic scissors in the desired direction, by keeping the handle pressed to carry out the cut.

NOTE

The thrust on the pneumatic scissors must be as uniform as possible.

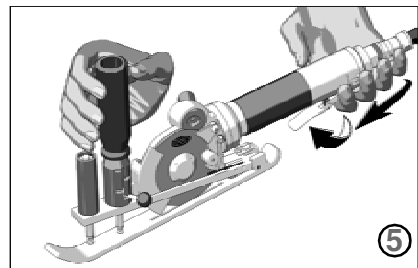
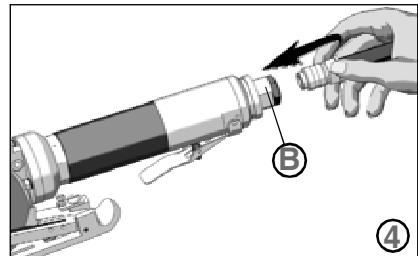
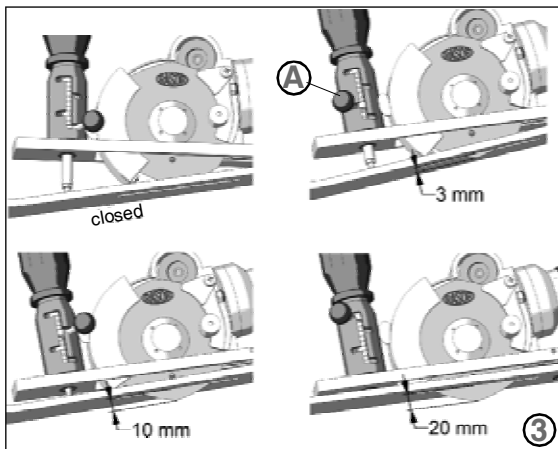

11. AIR PRESSURE GAUGE (OPTION)

The pneumatic scissors must be necessarily fed with lubricated air with a pressure of maximum 6 bar. Rasor® offers a reduction unit filter with a pressure gauge already calibrated with the quantity of oil to be delivered as option.

The unit shown also in picture 6 is made up of:

- 1 - pressure reducer;
- 2 - valve to drain the condensate;
- 3 - drop-feed oiler unit;
- 4 - oil tank;
- 5 - pressure gauge;
- 6 - condensate tank;
- 7 - pipe fitting to connect the quick connection to the network;
- 8 - pipe fitting to connect the quick connection to the scissor.

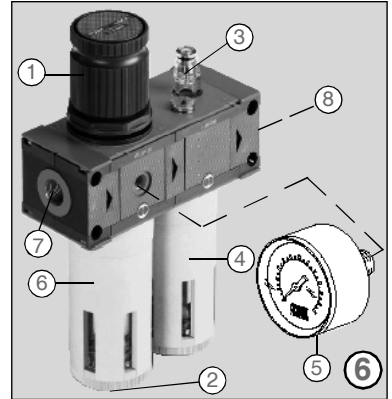

For the use and maintenance read the instruction sheet supplied with the filter.

12. SHARPENER ADJUSTMENT

After using the machine for some hours without interruption, or if the machine cutting capacity is reduced, it is necessary to sharpen the blade. To carry out this operation, start the blade and press sharpener "2" on the blade itself (by means of push button "1", as shown in picture 7) for 3-4 seconds. Repeat this operation 2-3 times.

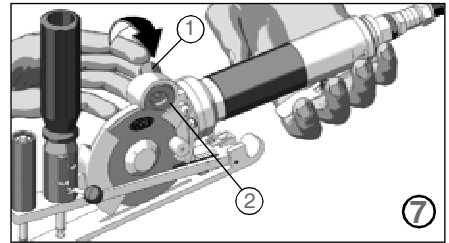

WARNING



The sharpener button can be used only if the transparent guard is completely lowered.

13. LUBRIFICATION

Every 3-4 working hours, it is necessary to lubricate the gear pair. In order to carry out this operation, remove protective plug "A" located on the head of the pneumatic scissors and fill it with the grease supplied. Screw plug "A" again a few turns. Screw plug "A" a few turns every 2-3 working hours (see picture 8).

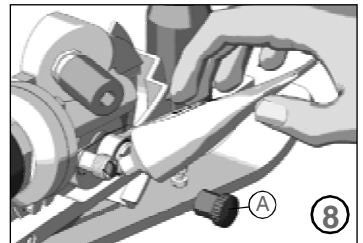

WARNING



The blade must never be dirty with grease or oil.

14. BLADE REPLACEMENT

If the blade is no more able to cut (even after repeating the sharpening operation several times) it is necessary to replace it. In order to carry out this operation, use butterfly key "1" and drift "3" locking the blade (shown in picture 9).

In order to replace the blade, proceed as follows:

- 1) Use some protective gloves in compliance with the Local Law of the Country where the machine is to be used (use of personal protection devices);
- 2) Remove front movable safety protection "A" and the spring "B", by unscrewing the slotted screw "C" through the proper screwdriver (not supplied by the manufacturer) and by extracting the two washers "D", as shown in picture 10.
- 3) Remove the rear fixed safety protection "E", the spring "F" and the ring "G" by unscrewing the slotted screw "H" by means of the proper screwdriver (not supplied by the manufacturer), as shown in picture 11.
- 4) Insert drift "3" (see picture 12) in hole "I" in order to lock the blade (the hole on the blade must correspond to the hole in the structure).
- 5) Use butterfly key "1" in order to unscrew nut "L" and remove blade "M" (see picture 12).
- 6) Replace the worn blade with the new one "2", being careful to center the blade on the shaft, in the correct position, and remember to assemble it with side with the writing RASOR positioned towards the external side of the pneumatic scissors.
- 7) Assemble all the components again and carry out some cutting and sharpening tests.

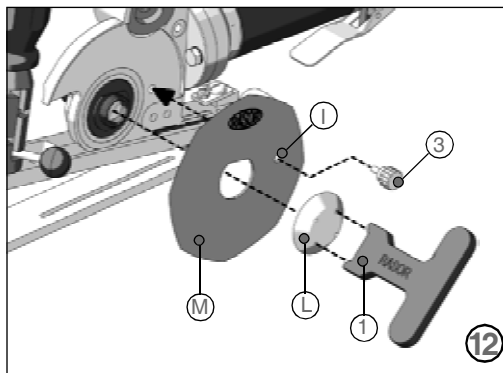
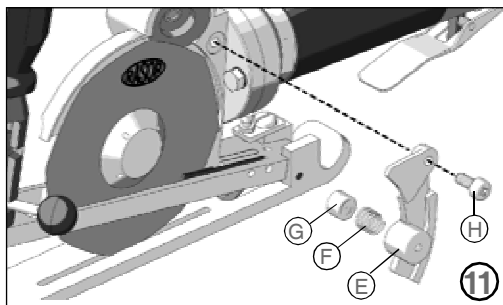
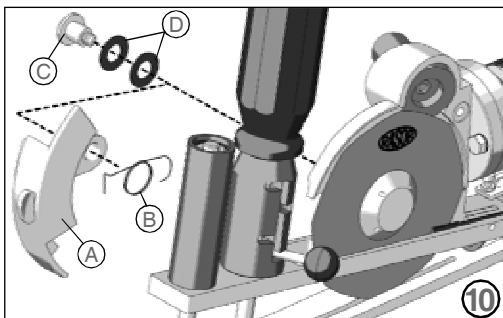
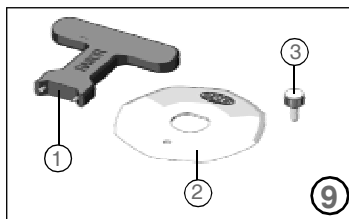

15. TROUBLESHOOTING

EN
28

✘ PROBLEM	⇒ SOLUTION
The fabric is not cut or it gets stuck between the blade and the counterblade	Check the counterblade integrity
	Check the kind of fabric
	Sharpen the blade
	Check the fabric thickness
	Check the compatibility between blade and fabric
The pneumatic scissors are noisy	Make sure that the turbine turns correctly
	Reduce the feeding speed
	Carry out the lubrication
	Disassemble the blade and remove the material residues
	Check the silencer
The scissors start slowly or work intermittently	Check the wear of the gear couple
	Check the integrity of the pneumatic circuit
	Set the working pressure at 6 bar
	Check the internal diameter of the pipes and connections (min. \varnothing 8 mm)

16. SPARE PARTS / EXPLODED VIEW

CODE	DESCRIPTION	CODE	DESCRIPTION	CODE	DESCRIPTION	CODE	DESCRIPTION
86THSSTF	8-FACES 86 mm BLADE IN H.S.S. STEEL, COATED WITH TEFLON	FP 86112	MOTOR FLANGE BEARING	FP 86158A	LOWER SLIDE	SW108900	SHARPENER BUSH
F 7056	COUNTERBLADE FIXED SCREW	FP 86113	FRONT FLANGE	FP 8615801B	UPPER SLIDE	SW109000	\varnothing 6 mm EMERY SPRING
FP 86009	COUPLING FLANGE	FP 86114	ROTOR	FP 86159CPL	COMPLETE RING GEAR	SW109100	SHARPENER CAP WITH BEARING
FP 86010	PISTON GUIDE	FP 86115	ROTOR BLADE	FP 86160	SELECTOR	SW109200	SHARPENER CAP FIXING SCREW
FP 86011	PISTON GUIDE O' RING	FP 86116	POSITIONING PIN	FP 86161	SHAFT	SW109300	STEEL WASHER
FP 86012	PISTON GUIDE O' RING	FP 86117	REAR FLANGE	FP 86161CPL	COMPLETE SELECTOR	T102906	LEVER FIXING PIN
FP 86013	PISTON	FP 86118	REAR FLANGE BEARING	FP 86162	THREADED PIN	T102909	RATCHET FOR LEVER SERIES 2002
FP 86013CPL	COMPLETE PISTON WITH GUIDE	FP 86119	REAR FLANGE CAP	FP 86163	SELECTOR ADJUSTING KNOB	T102910	RATCHET SPRING
FP 86014	STOP RING	FP 86120	CYLINDER	FP 86164	SELECTOR SPRING	T104501	CONVEX WASHER
FP 86017	VALVE	FP 86120CPL	COMPLETE TURBINE	FP 86165	SPACER	T1045RC	FRONT PROTECTION FIXING SCREW
FP 86018	VALVE O' RING	FP 86121	O'RING GASKET	FP 86166	STOP RING	T104700	GREASER CAP
FP 86019	STEEL BALL	FP 86122	MOTOR CASE	FP 86167	PLASTIC HANDLE	T104800	OILER
FP 86020	SPRING	FP 8612301	CONTROL HEAD	FP 86168	STEEL PIN	T105200	SUPPORT FIXING SCREW
FP 86021	SILENCER HOUSING O'RING	FP 8612301CPL	COMPLETE CONTROL HEAD	FP 86171	ADJUSTING SCREW	T105300	WASHER
FP 86022	SILENCER HOUSING	FP 86130	1/4" CONNECTOR WITH FILTER	FP86175	COUNTERBLADE IN HARD METAL	T105600	SHAVING WASHER
FP 86025	Bronze silencer filter	FP 86135	REAR CARTER	FP86176	SUPPORTING FOOT	T105700	BEARING FIXING RING NUT
FP 86026	SMALL REDUCTION UNIT O' RING	FP 86135CPL	REAR PROTECTION SET	FP86177	UPPER SLIDE FIXING ALLEN SCREW	T105800	GEAR BEARING
FP 86028	REDUCTION UNIT	FP 86136	4MM SCREW FOR CARTER FIXING	FP 86178	RETURN BUSH	T106000	LEFT SCREW FOR GEAR FIXING
FP 86100CPL	COMPLETE PNEUMATIC MOTOR	FP 86137RC	FRONT PROTECTIVE GUARD	FP 89178CPL	COMPLETE RETURN BUSH	T106100	SUBBLADE RING
FP 86101	GEAR WORM SCREW	FP 86137RCCLP	FRONT PROTECTION SET	FP 86198	THREADED RING NUT	T106300	BLADE FIXING RING NUT
FP 86101CPL	COMPLETE GEAR COUPLE	FP 86138RC	COMPLETE MOTOR SUPPORT	P029	RUBBER HOSE	T107500	BLADE DISASSEMBLING KEY
FP 86102	ELASTIC PIN	FP 86140L	FOOT FIXING SCREW	SW104102	OILER RING	T107600	BLADE LOCKING DRIFT
FP 86103	FRONT SHAFT BEARING	FP 86140R	TOOTHED WASHER	SW104103	OILER SPRING	T107900	LUBRICATING GREASE
FP 86104	SNAP RING	FP 86146	COMPLETE CONTROL LEVER	SW108600	EMERY TYPE \varnothing 25 x9 x 6	T107905	LUBRICATING OIL (30 ml)
FP 86106	REAR SHAFT BEARING	FP 86150	COUPLING SHAFT	SW1086CPL	COMPLETE EMERY GROUP	T105400	ANTI-FRICTION BUSH
FP 86107	JOINT	FP 86150CPL	COMPLETE COUPLING SHAFT	SW108700	EMERY PIN	FP095	HANDLE FOR HOOK
FP 86110	COMPENSATOR RING	FP 86157	FRONT PROTECTION SPRING	SW108800	\varnothing 11 mm EMERY SPRING		

ACCESSORIES

CODE	DESCRIPTION	CODE	DESCRIPTION
P170	FEMALE QUICK COUPLING - 1/4" GAS	P173	AIR PIPE \varnothing 8x6 mm
P171	MALE QUICK COUPLING - 1/4" GAS		



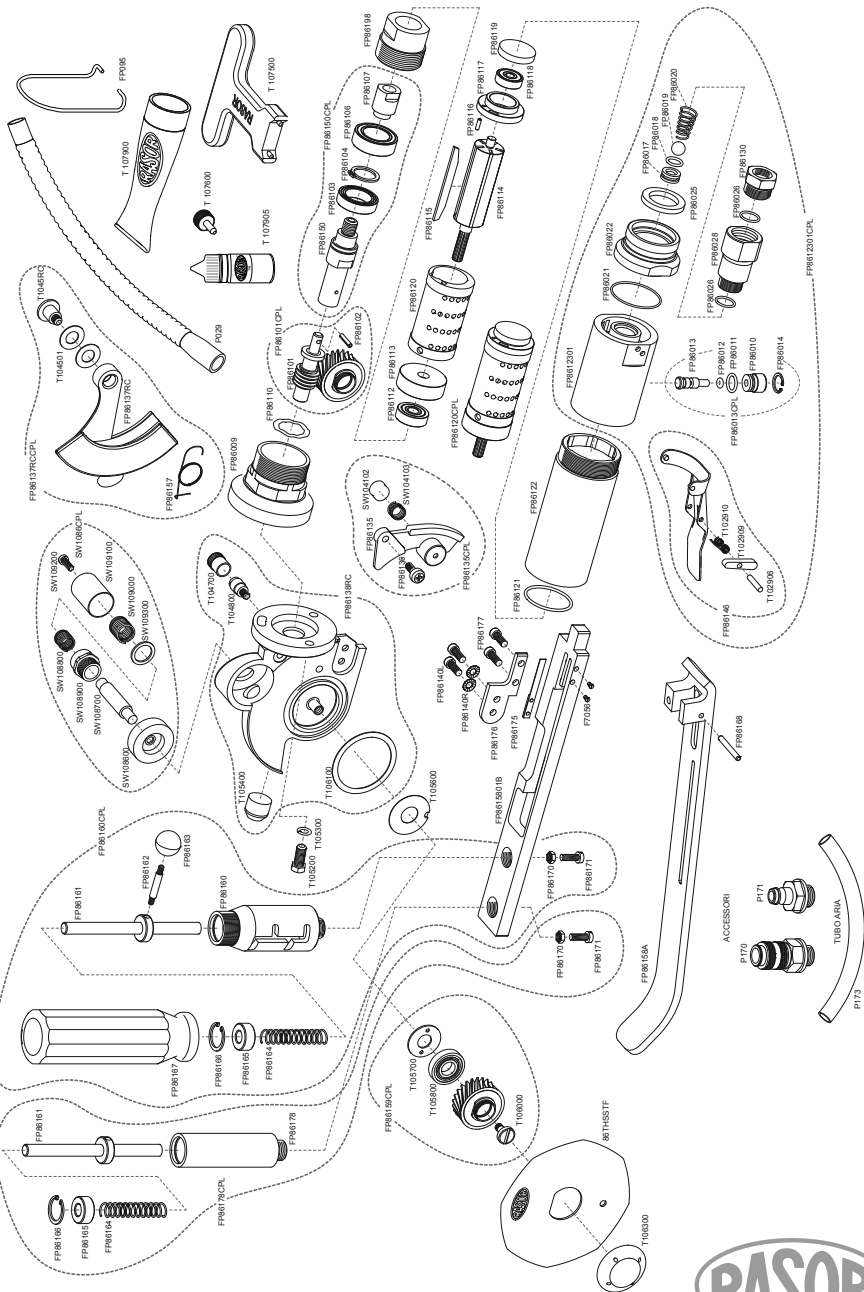

ACCESSORI
 P170
 P171
 TURBO-ARA
 P172



WARRANTY

Rasor® Elettromeccanica S.r.l. pneumatic scissors have a 12 month warranty from the date indicated on the last page of this manual, except in case of different written agreements. The warranty covers all manufacturing and material defects. Replacement and repair operations are covered only if carried out by our company and at our workshop.

In case of returned goods for repair under warranty, **the Customer must send to Rasor® always the complete machine. Repairs under warranty of single faulty components are not accepted.**

The material to be repaired must be sent CARRIAGE FREE.

Once the machine has been repaired, it will be sent CARRIAGE FORWARD to the customer. The warranty covers neither technicians' intervention on site nor the machine disassembly from the installation place.

If for practical reasons, one of our technicians is sent to the premises, the customer will be charged the costs plus the travelling expenses.

The warranty does not include:

- ✎ failure caused by wrong use or assembly,
- ✎ failure caused by external agents,
- ✎ failure caused by lack of maintenance or negligence;
- ✎ blades and components subject to wear.

WARRANTY FORFEITURE:

- ✎ In case of arrearage or other breaches of contract,
- ✎ Whenever changes or repairs are carried out on our pneumatic scissors without our prior authorization,
- ✎ Whenever the serial number is tampered with or cancelled,
- ✎ Whenever the damage is caused by improper use, bad treatment, bumps, falls and other causes not due to normal working conditions,
- ✎ Whenever the unit seems tampered with, dismantled or previously repaired by unauthorized staff,
- ✎ In case the pneumatic scissors are used for purposes that are different from the ones described in this manual.

All repair operations carried out under warranty do not interrupt its duration.

All disputes will be settled in the court of justice of Milan (Italy).

We thank you in advance for the attention you will pay to this manual and we invite you to inform us of any change you deem necessary to improve it and make it more complete.

RASOR ELETTROMECCANICA SRL

Via Vincenzo Caldesi 6

20161 Milan · Italy

ph. +39 02 66 22 12 31

fax +39 02 66 22 12 93

info@rasor-cutters.com

www.rasor-cutters.com

FOLLOW US:

